

MAGNA3 50-120 F (N)

1 x 230 V, 50/60 Hz

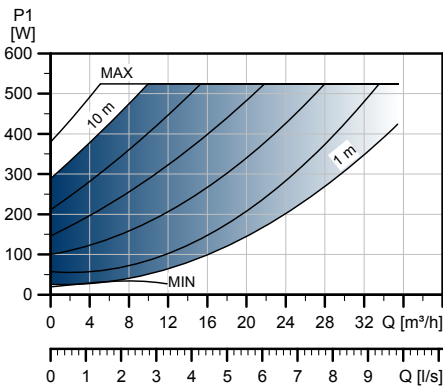
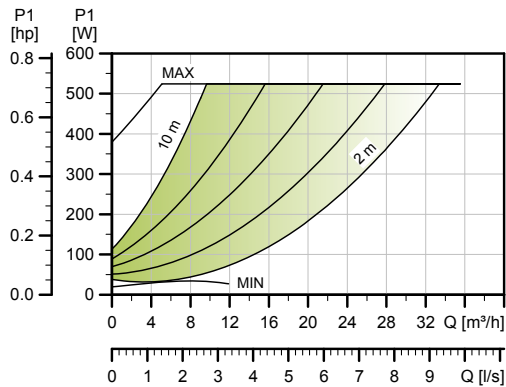
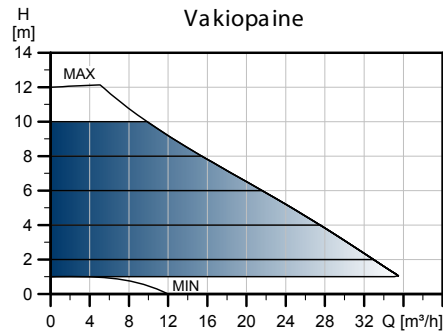
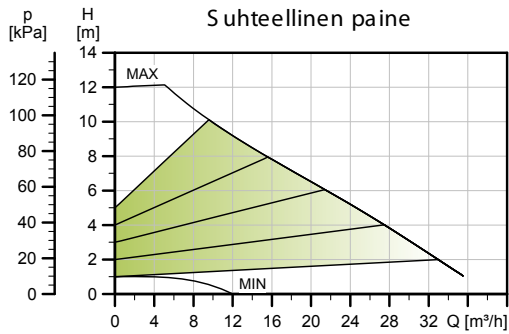

TM05 3743 1912

Nopeus	P1 [W]	I _{1/1} [A]
Min.	20	0,22
Maks.	536	2,37

Pumppu on varustettu ylikuormitusuojalla.

Nettopaino [kg]	Bruttopaino [kg]	Pakk. tilav. [m ³]
17,6	21,1	0,05

Liitännät:

Käyttöpaine:

Nesteen lämpötila:

Saatavana myös:

EEL-ominaisarvo:

Katso *Vastalaipat*, sivu 39.

Maks. 1,0 MPa (10 bar).

Saatavana myös maks. 1,6 MPa (16 bar).

-10 °C ... +110 °C (TF 110).

Pumppupesä ruostumatonta terästä, tyyppi N.

0,18.

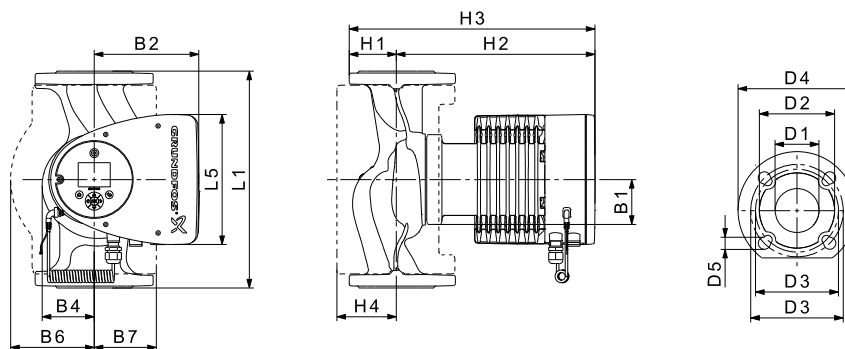

TM05 2204 3612

Pumpputyyppi	Mitat [mm]															
	L1	L5	B1	B2	B4	B6	B7	H1	H2	H3	H4	D1	D2	D3	D4	D5
MAGNA3 50-120 F (N)	280	204	84	164	73	127	127	72	304	376	97	50	102	110/125	165	14/19

Katso tuotenumerot sivulta 106.